

STAGE COLOUR 1200 HALO

Lampade alogene a tensione di rete
Mains voltage halogen lamp

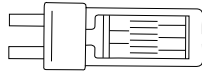

1200W G22 HALOGEN

Cambiacolori professionale estremamente versatile. Sostituisce egregiamente grandi quantità di spot convenzionali o diffusori wash.

Professional colourchanging unit and very versatile. It can easily replace big numbers of conventional lens spot, Par spots and floodlights.



CODE K1813

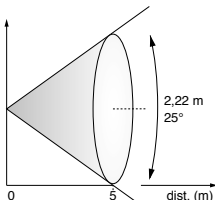

CE
IP 20

Specifiche tecniche

- Lampada Cod. L 151 - CP/93 230V 1200W
- Prima ruota colori: 5 colori + bianco
- Seconda ruota colori: 5 colori + bianco
- Dimmer 0-100%
- Effetto strobo
- Funzione Master/Slave
- Programmi automatici interni
- Microfono interno
- Display: selezione delle funzioni con display digitale
- Possibilità di roteare la visione del display di 180°
- Reset remoto e locale
- Autotest per tutte le funzioni
- Visualizzazione del canale DMX
- Programma salvabile:
editare e salvare il programma in una eeprom interna attraverso il pannello frontale o un comando esterno. Si possono salvare fino a 48 scene, attivabili direttamente dal pannello frontale
- 4 canali DMX
- Dimensioni: 47 x 41 x 45 cm.
- Peso: 18 Kg
- **Accessori:**
- Deflettore orientabile con alette direzionabili Codice K1813

Technical specifications

- Lamp: Code L 151 - CP/93 230V 1200W
- First color wheel: 5 colors + white
- Second color wheel: 5 colors + white
- Dimmer 0-100%
- Strobe effect
- Master/Slave function
- Automatic programs
- Built-in microphone
- Display: digital address and function setting
- Display: can turn 180° if the mounting location so requires
- Local or remote resetting
- Auto test for all functions
- Value of each DMX channel can be displayed
- Save program:
edit and save the program to the incorporated EEPROM through the front control panel or external controller, can save maximum 48 scenes, and run the saved program by the "run" menu from the front control panel
- 4 DMX channels
- Dimensions: 47 x 41 x 45 cm.
- Weight: 18 Kg
- **Accessories:**
- Four-leaf rotating barndoor Code K1813

RAINBOW CAN

Lampade alogene a tensione di rete
Mains voltage halogen lamp

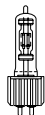

Unità cambia colori a 3 canali pilotata da segnale digitale DMX 512. Cambia colori RGB (somma di colori) per 3 lampade HPL 575. Corpo in alluminio, munito di ventola di raffreddamento.

RGB halogen electronic colour changer for 3 HPL 575 lamps and built-in 3 stage dimmer pack. It is handy, compact and cooled by a no noise fan, driveable by a DMX controller.

CODE K1804



Specifiche tecniche

- 3 lampade HPL 575W G 9,5
- Cod. L 137/L 138
- 3 canali DMX
- Infinite combinazioni di colore
- Dimmer interno controllabile via DMX
- Ventilatore
- Dimensioni: 360x250x380 mm
- Peso: 4,5 Kg

Technical specifications

- 3 x G 9,5 HPL 575W lamps
- Code L 137/L 138
- 3 DMX channels
- Unlimited colour combinations
- Built-in DMX 512 dimmer
- Fan
- Dimensions: 360x250x380 mm
- Weight: 4,5 Kg

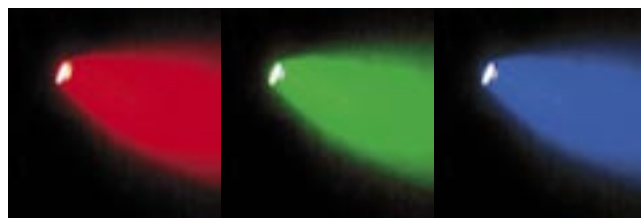

CE
IP 20

RGB ATMOSPHERE

Unità cambiacolori a 3 canali pilotata da segnale digitale DMX 512. Cambia colori RGB (somma di colori) per 3 lampade 500W. Corpo in alluminio, munito di ventola di raffreddamento e di deflettore con alette orientabili per meglio delimitare il fascio luminoso.

RGB halogen electronic colour changer for 3 500W lamps and built-in 3 stage dimmer pack. It is handy, compact and cooled by a no noise fan, driveable by a DMX controller. Fitted with adjustable barndoor accessory to ensure precise beam shaping.

Lampade alogene a tensione di rete
Mains voltage halogen lamp

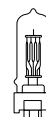

CODE K1806



Specifiche tecniche

- 3 lampade 500W GY 9,5
- Cod. L 135/L 136
- 3 canali DMX
- Infinite combinazioni di colore
- Dimmer controllabile via DMX
- Ventilatore
- Dimensioni: 320x310x335 mm
- Peso: 5,5 Kg

Technical specifications

- 3 x GY 9,5 500W lamps
- Code L 135/L 136
- 3 DMX channels
- Unlimited colour combinations
- Built-in DMX 512 dimmer
- Fan
- Dimensions: 320x310x335 mm
- Weight: 5,5 Kg



CE
IP 20

RGB PANORAMA

Lampade lineari a tensione di rete
Halogen linear lamp

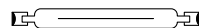

Max 500W R7s 230V

CODE K1810

Proiettore cambia colori panoramico con filtri dicroici di colore rosso, verde e blu (RGB). La miscelazione dei tre colori di base da la possibilità di generare infiniti altri colori. Questa unità elettronica può essere controllata con segnale digitale DMX 512 o in modalità master/slave per funzionare in modo autonomo. Utilizza 3 lampade da 300/500W R7s. Munita di deflettore con alette direzionali per meglio delimitare il fascio luminoso.

Panoramic colour-changing projector with dichroic RGB filters. Mixing the three basic colours enables endless colours to be created. This electronic unit can be controlled with DMX 512 digital signals or in master/slave mode for stand-alone operation. Uses three 300/500W R7s lamps. Fitted with adjustable barndoor accessory to ensure precise beam shaping.

Specifiche tecniche

- 3 lampade: Cod. L 155 - 300W R7s 117mm oppure Cod. L 160 - 500W R7s 117mm
- 7 canali DMX
- Infinite combinazioni di colore
- Dimmer controllabile via DMX
- Ventilatore
- Dimensioni: 26x41x19 cm
- Colore: nero
- Peso: 5,5 Kg

Technical specifications

- 3 lamps: Code L 155 - 300W R7s 117mm or Code L 160 - 500W R7s 117mm
- 7 DMX channels
- Unlimited colour combinations
- Built-in DMX 512 dimmer
- Fan
- Dimensions: 26x41x19 cm
- Colour: black
- Weight: 5,5 Kg



IP 20

COLOUR TRUSS

Lampada dicroica a tensione di rete
Mains voltage dichroic lamp

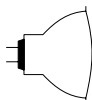

CODE K1808



IP 20

Cambia colori compatto RGB per strutture, con 3 lampade 50W 220V e dimmer interno. Controllabile via DMX o in modalità stand alone. Munito di una staffa regolabile di fissaggio.

Compact RGB colour changer for truss, with 50W 220V lamps and built-in 3 stage dimmer pack. It is driveable via DMX controller or by stand alone mode. Mounted with adjustable steel bracket.

LAMPAD E INCLUSE
LAMPS INCLUDED



Specifiche tecniche

- 3 lampade JCDR- 50W 220Volt Cod. L 101
- 3 canali DMX
- Infinite combinazioni di colore
- Dimmer interno controllabile via DMX
- Dimensioni: 140x140x200 mm
- Peso: 1,9 Kg

Technical specifications

- 3 lamps JCDR - 50W 220 Volts Code L 101
- 3 DMX channels
- Unlimited colour combinations
- Built-in DMX 512 dimmer
- Dimensions: 140x140x200 mm
- Weight: 1,9 Kg

COLOURWASH CMY 250

Cambiacolori professionale con sistema di filtri dicroici CMY per lampada a scarica MSD 250W.

Facile e chiara la selezione delle funzioni attraverso il display posto sul retro dell'apparecchio.

Questa unità elettronica può essere controllata con segnale digitale DMX 512 o in modalità master/slave per funzionare in modo autonomo.

La memoria contiene 48 scene pre programmate da utilizzare in modalità stand alone, automatico o a tempo di musica.

Lampada a scarica MSD 250/2
Discharge lamp MSD 250/2

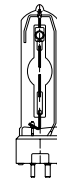

Professional colour-changing fixtures with dichroic CMY filter system. Used with MSD 250W discharge lamp.

User-friendly function selection by means of the display on the rear of the fixture.

This electronic unit can be controlled via DMX 512, or in master/slave mode for standing-alone operation.

The memory contains 48 pre-programmed scenes for use in stand-alone, automatic or music-sync mode.

Specifiche tecniche

- Lampada: Cod. L 506 - MSD 250W/2 GY 9,5
- Controllo via 11 canali DMX 512 o stand alone con funzione Master/slave
- 48 scene pre-programmate in funzione run di stand alone
- Possibilità di selezione delle scene in run di stand alone
- Possibile modifica delle scene con un controllo esterno
- Dimmer 0-100%
- Disco con colori aggiuntivi (5 colori + bianco)
- Filtri di correzione a 3200°K e 5600°K
- Filtro frost
- Filtro UV
- Effetto strobo
- Effetto shaper
- Funzione Mask
- Zoom 7° - 28°
- Cambia colori continuo nelle due direzioni
- Tensione di alimentazione: 220/230 Volts
- Massimo consumo: 440 Watts
- Defflettore orientabile con alette direzionali incluso

Technical specifications

- Lamp: Code L 506 - MSD 250W GY 9.5
- Control via 11 DMX 512 channels or in stand-alone mode, with Master/slave function
- 48 pre-programmed scenes in the stand-alone "run" function
- Possibility of selecting the scenes in stand-alone run function
- Possibility of changing the scenes with an external controller
- Dimmer 0-100%
- Wheel with additional colours
- 3200°K and 5600°K correction filters
- Frost filter
- UV filter
- Strobe effect
- Shaper effect
- Mask function
- Zoom 7° - 28°
- Continuous 2-way colour changer
- Power requirements: 220/230 Volts
- Maximum consumption: 440 Watts
- Adjustable rotating barndoors included

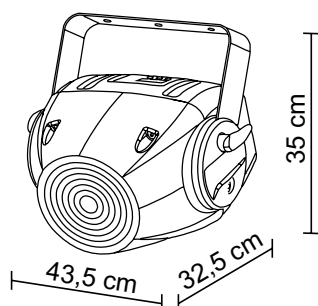

CODE K1800



CE

IP 20

OMNIPAR LED 180 RGB

Illuminatore cambia colori con sistema RGB a 180 led.
Robusto e compatto è realizzato in pressofusione in lega d'alluminio.
Il particolare design lo rende adatto ad ogni tipo di ambiente.
Alimentato direttamente alla rete elettrica 220/240 Volts, non ha limiti di numero come nelle versioni con alimentatore nelle quali per ogni uscita esiste una quantità massima di apparecchi collegabili.
Le sue numerose funzioni possono essere controllate direttamente attraverso microinterruttori posti sull'apparecchio o via segnale digitale DMX 512.
E' inoltre dotato di un supporto per l'eventuale utilizzo di un filtro diffusore.

Cambia colori con tecnologia LED
Colourchanger with LED technology

CODE K2052

Colour-changing illuminator with 180-LED RGB system.
Sturdy and compact – built in die-cast aluminium alloy.
Its smart lines make it ideal for any environment.
Powered directly by the 220/240 Volts mains supply, so there's no limit to the number of units, as is the case with versions with power supplies, with which a limited number of fixtures can be connected to each output.
Its numerous functions can be controlled directly by micro-switches mounted on the unit, or via DMX 512 digital signals.
It's also fitted with a holder for use with a frost filter.

Specifiche tecniche

- 180 leds: 60 rossi/60 blu/60 verdi
- Cambio dei colori graduale con sistema RGB
- Effetto stroboscopico
- Infinite combinazioni di colore
- Controllo 6 canali con segnale digitale DMX 512
- Attivazione a tempo di musica
- Attivazione automatica
- Numerosi programmi in memoria
- Alimentazione: 220/240 volts
- Consumo: 50W

Technical specifications

- 180 leds: 60 red/60 blue/60 green
- Stepless RGB colour changing
- Strobe effects
- Unlimited colour combinations
- 6 channels DMX control system
- Sound activated
- Stand alone
- Programmed scenes
- Power: 220/240 Volts 50 Hz
- Consumption: 50W

PORTAFILTRO
INCLUSO

FILTERFRAME
INCLUDED

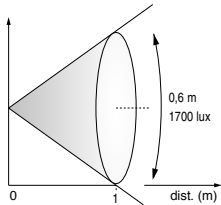

Accessori

- Deflettore orientabile con alette direzionali Cod. K1355

Accessories

- Four-leaf rotating barndoor code K1355



BABYPAR LED 62 RGB

Illuminatore cambia colori con sistema RGB a 62 led.
Di piccole dimensioni è realizzato in pressofusione in lega d'alluminio, si adatta ad ogni tipo d'ambiente.
Alimentato direttamente alla rete elettrica 220/240 Volts, non ha limiti di numero come nelle versioni con alimentatore nelle quali per ogni uscita esiste una quantità massima di apparecchi collegabili.
Le sue numerose funzioni possono essere controllate direttamente attraverso microinterruttori posti sull'apparecchio o via segnale digitale DMX 512.
E' inoltre dotato di un supporto per l'eventuale utilizzo di un filtro diffusore.

Cambia colori con tecnologia LED
Colourchanger with LED technology

CODE K2050

Colour-changing illuminator with a 62-LED RGB system.
Small unit manufactured in die-cast aluminium alloy, suited to any kind of environment.
Powered directly by the 220/240 Volts mains supply, so there's no limit to the number of units, as is the case with versions with power supplies, with which a limited number of fixtures can be connected to each output.
Its numerous functions can be controlled directly by micro-switches mounted on the unit, or via DMX 512 digital signals. It's also fitted with a holder for use with a frost filter.

Specifiche tecniche

- 62 leds: 20 rossi/22 blu/20 verdi
- Cambio dei colori graduale con sistema RGB
- Effetto stroboscopico
- Infinite combinazioni di colore
- Controllo 6 canali con segnale digitale DMX 512
- Attivazione a tempo di musica
- Attivazione automatica
- Numerosi programmi in memoria
- Alimentazione: 220/240 volts
- Consumo: 15W

Technical specifications

- 62 leds: 20 red/22 blue/20 green
- Stepless RGB colour changing
- Strobe effects
- Unlimited colour combinations
- 6 channels DMX control system
- Sound activated
- Stand alone
- Programmed scenes
- Power: 220/240 Volts 50 Hz
- Consumption: 15W

PORTAFILTRO
INCLUSO

FILTERFRAME
INCLUDED

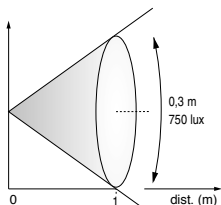

Accessori

- Deflettore orientabile con alette direzionali Cod. K1355

Accessories

- Four-leaf rotating barndoor code K1355



WALL PAINTER

CODE K2002



CE
IP 20

Wall Painter LED system crea un eccellente cambio di colori con effetto wash.
Può essere montato anche a soffitto e installato in qualsiasi ambiente.
E' fornito di 8 programmi pre impostati che possono essere eseguiti in modalità automatica ed uno dedicato al controllo musicale.
Wall Painter è compatibile con il protocollo digitale DMX 512.

*The Wall painter LED system provides an excellent colour changing wash effect.
It can be mounted on the ceiling and installed around the stage etc.
It features 8 pre-programmed chase sequence, a sound-active mode and is compatible with the DMX 512.*

Caratteristiche tecniche:

- 648 LED (81 x 8)
- Controllabile via DMX (6, 12, 24, 48 canali)
- Attivazione musicale
- Tensione di alimentazione: 230V 50Hz
- Consumo: 115W
- Fusibile di protezione: 1,5A
- Dimensioni: 48x33x9 cm
- Peso: 6,1 Kg

Technical specifications

- 648 LED (81 x 8)
- Controllable via DMX (6, 12, 24, 48 channels)
- Sound activated
- Power supply: 230V 50Hz
- Consumption: 115W
- Fuse: 1,5A
- Dimensions: 48x33x9 cm
- Weight: 6,1 Kg

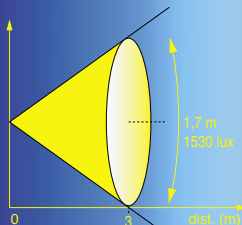

Powerful colourchanger



LED COLOUR CHANGING SYSTEMS



Versione con 80 LED per unità, è particolarmente adatta per illuminare ambienti di medio-grandi dimensioni.

Version with 80 LEDs for each unit is suitable for medium-large venues.

LED SYSTEM RGB 80-S SURFACE MOUNT

COMPOSIZIONE DEL SISTEMA

- 8 illuminatori in alluminio con 80 LED cad.:
- 27 Rossi, 18 Verdi e 35 Blu
- 1 Driver 80
- 4 cavi di collegamento da 3 metri
- 4 cavi di collegamento da 6 metri

FUNZIONI

- Sistema di colori RGB
- Dimmer da 0 a 100%
- Strobo da 1 a 29 fps
- Effetto strobo pulsante
- Controllabile via DMX da 6 a 48 canali
- Attivazione automatica
- Attivazione musicale

SYSTEM FEATURES

- 8 aluminium lanterns with 80 LEDs each:
- 27 Red, 18 Green and 35 Blue
- 1 Driver 80 controller
- 4 pcs. 3 meter cables
- 4 pcs. 6 meter cables

FUNCTIONS

- RGB additive colour mixing
- Dimmer from 0 to 100%
- Strobe from 1 to 29 fps
- Strobe pulse effect
- 6/48 CH DMX control
- Stand alone
- Sound activated

- Dimensioni/Dimensions: 140x190x120 mm
- Peso/Weight: 1,25 Kg

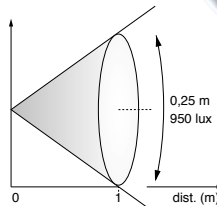

IP 20



LED SYSTEM RGB 80-R versione da incasso LED SYSTEM RECESSED RGB 80-R

CODE K2010



IP 20

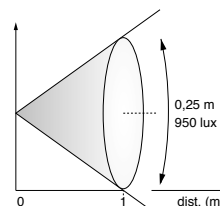

- Dimensioni/Dimensions: 210x210x110 mm
- Peso/Weight: 1,4 Kg



CHAMELEON

Lampada dicroica bassa tensione
Low voltage dichroic lamp



VERSIONE DA INCASSO / RECESSED CODE K1382



Cambia colori con filtri dicroici per illuminazione d'ambiente ed architettura d'interni. Disponibile in due modelli: da incasso e da superficie. Possibilità di controllo con segnale DMX 512 o tramite centralina dedicata (codice K1385).

Downlight colour changing with dichroic filters projectors for indoor architectural and display applications. Two models available: for and applications. DMX512 controllable or with controller (code K1385).

4CH DRIVER UNIT CODE K1384



CONTROLLER CODE K1385



IP 20

Specifiche tecniche

- Lampada: 50W 12V MR16
Cod. L 080/L 081
- 6 colori dicroici + bianco
- Controllabile via 4CH-DRIVER UNIT cod. K1384
- IN/OUT via connettore a 6-vie RJ11
- Tensione di alimentazione: 12V
- Dimensioni K1380: 160X110X165 mm - 0,9Kg
- Dimensioni K1382: 153X145X130 mm - 0,7Kg

Unità di distribuzione a 4 canali per 4 cambia colori per canale (max 16)

- Uscita con 4 connettori a 6-vie RJ11.
- Segnale d'ingresso dal CONTROLLER (cod.K1385) con connettore a 4-vie RJ11
- DMX in / DMX out via connettori a 3 pin XLR
- 4 canali DMX 512
- Alimentazione: 220/240 Volts 50 Hz
- Dimensioni: 215x75x95 mm

Centralina controllo per Chameleon

- Selezione manuale dei colori
- 8 presets programmabili
- 8 scene programmabili
- 8 programmi in memoria
- Intervallo fra le scene variabile da 5 sec a 60 min.
- Alimentatore: 12 Volts fornita dal 4CH DRIVER
- Dimensioni: 145x85x42 mm

Accessori

- Trasformatore elettronico 100W (per 2 lampade)
Cod. K1390

Technical specifications

- Lamp: 50W 12V MR16
Code L 080/L 081
- 6 dichroic colours + white
- Controllable via: 4CH-DRIVER UNIT cod. K1384
- IN/OUT via 6-way RJ11 connector
- Power supply: 12V
- Dimensions K1380: 160X110X165 mm - 0,9Kg
- Dimensions K1382: 153X145X130 mm - 0,7Kg

4-channel distribution unit for use with up to four colour-changing fixtures per channel (max 16)

- 4 outputs with 6-way RJ11 connectors.
- Input signal from CONTROLLER (code K1385) via 4-way RJ11 connector
- DMX in / DMX out via XLR connectors
- 4 DMX channels
- Power supply: 220/240 Volts 50 Hz
- Dimensions: 215x75x95 mm

Controller for Chameleon

- Manually set colour
- 8 programmable presets
- 8 programmable scenes
- 8 factory-set programs
- Run programs from 5 sec to 60 minutes
- Power supply: 12 Volts from 4Ch-Driver
- Dimensions: 145x85x42 mm

Accessories

- Electronic transformer 100W (for 2 lamps)
Code K1390

VERSIONE DA SUPERFICIE / SURFACE MOUNT CODE K1380



IP 20



Configurazione del sistema per 16 unità

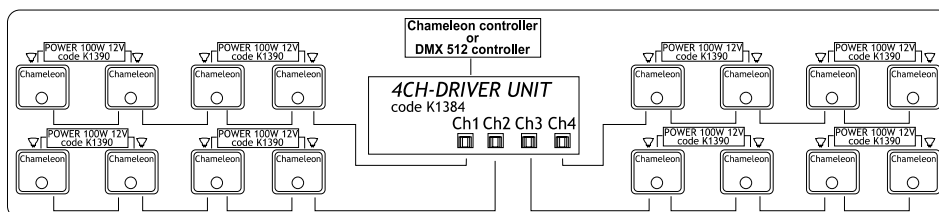

System Configuration with 16 units